

IMU 52 FAMILY

Inertial Measurement Unit

OVERVIEW

The IMU 52 family is a field and combat proven inertial system integrated into dozens of operational platforms. It is available in multiple performance grades to support versatility of platform performance. The IMU 52 uses the latest closed-loop fiber-optic gyro (FOG) and linear rebalanced accelerometer (optional MEMs) technology. This small, lightweight, high performance strap-down IMU (Inertial Measurement Unit) suited for navigation, stabilization and flight control for both defense and commercial applications. The IMU 52 is suitable for harsh vibration environments and is available in multiple configurations to meet different price and performance requirements.

SYSTEM HIGHLIGHTS

ARW: 0.07-0.008°/√hr.

- Jitter performance improvement
- Improved LOS stabilization

Scalable bias performance: 1°-0.1°/hr.

- CEP improvement
- Support future accuracy upgrades

Configuration alternatives:

- Hard mounted configuration – high bandwidth/LOS stabilization
- Vibration protected configuration for environmentally demanding applications

ITAR free

Excellent cost to performance ratio

Three different performance grades:

- Non-MTCR grade
- High performance grade
- Gyro-compass/navigation performance grade

IMU 52 CV (Commercial Version [Non-MTCR](#))

IMU 52CV is **Non-MTCR**, cost-effective and suitable for commercial applications (e.g. aerial mapping).

IMU 52

IMU 52 uses high performance over temperature sensors: 0.5 degree/hr gyroscope and 0.3mg accelerometer with extremely low noise levels.

IMU 52 XP (Enhanced Performance)

IMU 52-XP has gyrocompassing and navigation grade capabilities within the same form factor as the standard IMU 52.

IMU 52

Inertial Measurement Unit



PARAMETER	IMU 52-CV	IMU 52	IMU 52-XP
GYRO			
Gyro Bias Short Term Over Temp. (1 sigma)	>1 °/hr.	>0.5 °/hr.	>0.1 °/hr.
Gyro Angular Random Walk	0.07 °/√hr	0.02 °/√hr	0.008 °/√hr
Gyro Scale Factor Short Term Over Temp. (1 sigma)	<100 PPM	<100 PPM	<100 PPM
Gyro Dynamic Range	±1000 °/sec.	±1000 °/sec.	±1000 °/sec.
ACCELEROMETER			
Accelerometer Bias Short Term Over Temp. (1 sigma)	<2000 µg	<300 µg	<300 µg
Accelerometer Threshold	100 µg	10 µg	10 µg
Accelerometer Scale Factor Short Term Over Temp. (1 sigma)	1500 PPM	300 PPM	300 PPM
Accelerometer VRE	250 µg/g ²	20 µg/g ²	20 µg/g ²
Accelerometer Range	±30/±50 g	±30/±50 g	±30/±50 g
CHARACTERISTICS			
Size	0.8 Liter		
Weight	1000 Grams		
Power	13 W		
Temperature	-40 to 71°C		
Temperature Gradient	3 °C/min		
Power Input	28 VDC		
Interface	SDLC, RS422		
Data Rates	100 to 4800 Hz		
Sync	External or Internal		

Vibration Isolation

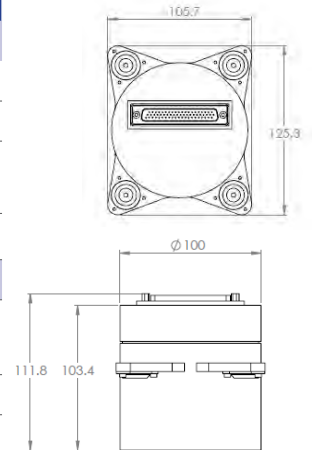

Hard Mounted

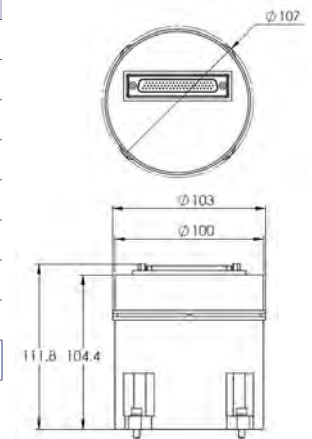

SYSTEM NAME	SYSTEM P/N	MOUNTING	INPUT VOLTAGE	ACCELEROMETERS	COMMUNICATION
IMU 52-G	220-1013	Hard Mounted	15/5 V	Quartz Rebalanced	SDLC
IMU 52-M	220-1005	Vibration Isolation	28 V	MEMS	RS-422
IMU 52-B	220-1007	Vibration Isolation	28 V	Quartz Rebalanced	RS-422
IMU 52-H	220-1010	Vibration Isolation	28 V	Hybrid	RS-422
IMU 52-K	220-1014	Hard Mounted	28 V	Quartz Rebalanced	RS-422

CIELO INERTIAL SOLUTIONS LTD.

info@cielo-inertial.com | www.cielo-inertial.com

5 Nahum Hefzadi St., P.O.Box 34429, Jerusalem 9134302 Israel | Tel: +972.2.6595339 | Fax: +972.2.6541221

